

MEUBELWIEL
DOUBLE WHEEL

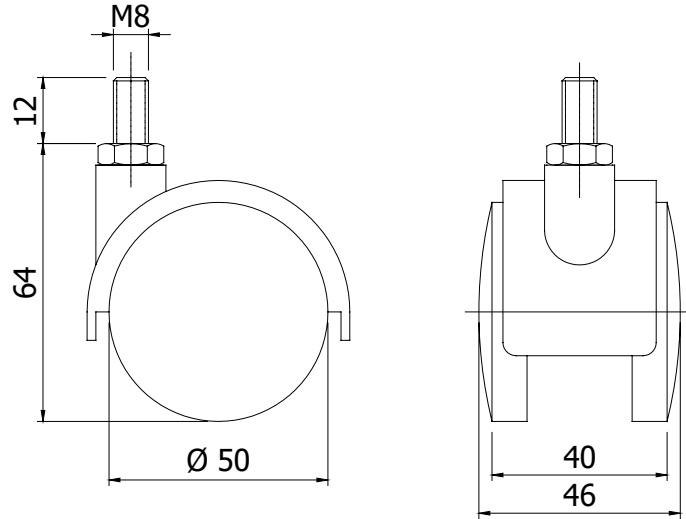
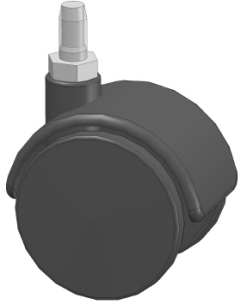

Techn. gegevens / techn. specifications:

- PA 6
- Zwart / black

Belasting / load:

- Max. 500 N

Kenmerk / feature:

- Voor het bevestigen aan de kopse zijde, dient draad M8 in het profiel getapt te worden / for mounting on the front side M8 thread should be tapped

Toepassing / application

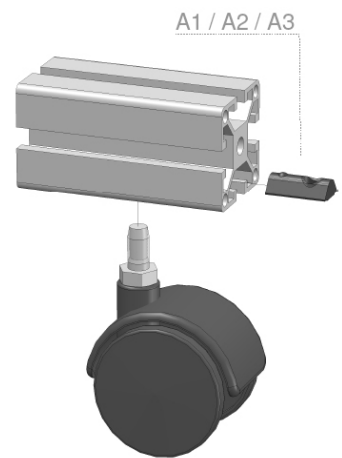
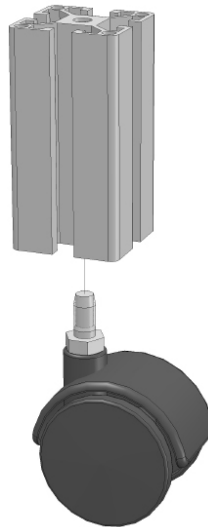

Afname / purchase Korting / discount

... stuks / piece	
10 stuks / pieces	10%

Omschrijving / description

Meubelwiel diam. 50, M8 x 12
Double wheel diam. 50, M8 x 12

Eenheid / unit

Stuk / piece

Art. code

144005

Accessoires / accessories

	A1	Sleufmoer 8E - M8 Sliding block 8E - M8	Stuk / piece	122315
	A2	Sleufmoer 8 - M8 Sliding block 8 - M8	Stuk / piece	122330
	A2	Sleufmoer 10 - M8 Sliding block 10 - M8	Stuk / piece	122350